

# LIMIT CONTROLLER



## NOVA PD570 Series

### Instruction Manual

PD570 & PD578

**PRECISION DIGITAL CORPORATION**

89 October Hill Road • Holliston MA 01746 USA  
Tel (800) 343-1001 • Fax (508) 655-8990



## Disclaimer

The information contained in this document is subject to change without notice. Precision Digital Corporation makes no representations or warranties with respect to the contents hereof, and specifically disclaims any implied warranties of merchantability or fitness for a particular purpose.

## Registered Trademarks

MODBUS® is a registered trademark of Schneider Automation Inc. All other trademarks mentioned in this document are the property of their respective owners.

**Visit our Web Site**  
<http://www.predig.com>

## Nova PD570 Series Model Number Guide

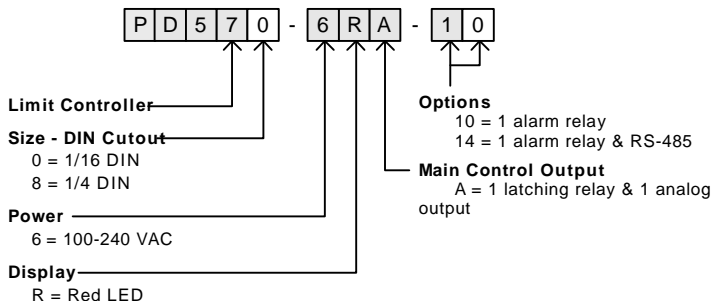

**Table of Contents**

|   |    |
|---|----|
| 1. Safety Guide and Specifications .....                | 5  |
| 1.1 Specifications .....                                | 7  |
| 2. Front Panel Buttons and LED Indicators .....         | 11 |
| 3. Parameter Map .....                                  | 12 |
| 4. Operation Flow Chart .....                           | 13 |
| 5. Controller Parameter Setup .....                     | 14 |
| 5.1 Input Group (G.IN) .....                            | 14 |
| 5.2 Control Group (G.CTL) .....                         | 18 |
| 5.3 Alarm Group (G.ALM) .....                           | 23 |
| 5.4 Retransmission Group (G.RET) .....                  | 26 |
| 5.5 Communication Group (G.COM) .....                   | 27 |
| 6. Error Display and Correction .....                   | 29 |
| 7. Installation .....                                   | 30 |
| 7.1 Dimensions and Panel Cutouts .....                  | 30 |
| 7.2 Panel Mounting .....                                | 32 |
| 7.3 Power Cable Specification .....                     | 33 |
| 7.4 Terminal Specification .....                        | 33 |
| 7.5 Terminal Assignment, Connections, and Ratings ..... | 34 |

---

|  |    |
|--|----|
| 7.6 Grounding and Power Cable Connection .....   | 36 |
| 7.7 Signal Input Connection .....                | 36 |
| 7.8 Retransmission Output Connection (RET) ..... | 37 |
| 7.9 Relay Output Connection (RELAY) .....        | 37 |
| 7.10 Use of an External Relay .....              | 38 |
| 7.11 Communication Wiring (RS485) .....          | 39 |

## Appendix

|                            |    |
|----------------------------|----|
| Table of D-Registers ..... | 40 |
|----------------------------|----|

## Tables and Figures

|  |    |
|--|----|
| Table 1: Universal Input Selection .....                                 | 14 |
| Table 2: Alarm Selection .....   | 24 |
| Fig 1: Temperature Bias .....  | 16 |
| Fig 2: Bias Formula Calculation .....                                    | 16 |
| Fig 3: Operation of Limit Functions with O.ACT set to REV .....          | 19 |
| Fig 4: Operation of Limit Functions with O.ACT set to FWD .....          | 19 |
| Fig 5: Example of Limit Control Relay Operation and Reset Function ..... | 20 |
| Fig 6: Alarm Operation .....   | 24 |

## 1. Safety Guide and Specifications



The following safety symbols are used in this manual

- (1) This symbol notifies the user of specific information relating to the safe operation of the controller. Information noted with this symbol must be observed to protect the user from injury and to prevent damage to the product.
  - (A) For User: Be aware of this marking in the manual and refer to the explanation in the manual to prevent injury and damage.
  - (2) For Installer: Study the warnings marked to prevent injury and damage.



- (2) Functional earth terminal: This symbol indicates that the terminal must be connected to ground.



- (3) This symbol indicates additional information on the features of the product.



- (4) This symbol directs the reader to further information on the current topic.



### Precautions Regarding This Instruction Manual

- (1) This manual must be kept in the possession of the end user and in a suitable place for the operator to study and to check the functions of the product.
- (2) The installer and operator should carefully study and understand how to operate this product before use.
- (3) This manual describes the functions of the product. Precision Digital Corporation does not guarantee that the functions will suit a particular purpose.
- (4) The contents of this manual have been reviewed for accuracy and correctness. However, should any errors or omissions come to the attention of the user, contact technical support as listed on the back of this manual.



### Safety Procedures and Unauthorized Modification Warning

- (1) In order to protect this product and the system controlled by it against damage and ensure its safe use, make certain that all of the safety instructions and precautions in this manual are strictly adhered to.
- (2) Precision Digital Corporation does not guarantee safety if the products are not handled in accordance with this instruction manual.
- (3) If separate protection or safety circuits are to be installed in the system which is controlled by this product, ensure that such circuits are installed external to this product.
- (4) Do not make modifications or additions internally to the product. It may cause personal injury to the user or damage to the product.
- (5) Contact technical support as listed on the back of the manual for warranty and repair issues.
- (6) Exposure to excessive moisture, electrical overloads, or mechanical vibration may damage the product.



### Limited Liability

Precision Digital Corporation assumes no liability to any party for any loss or damage, direct or indirect, caused by the use of or any unpredictable defect of the product.

**CAUTION**

## Operational Environment Precautions

- (1) Only operate the controller when it is properly installed.
- (2) When installing the controller, select a location where:
  - Rear terminals are protected from accidental contact.
  - Mechanical vibrations are minimal.
  - No corrosive gas is present.
  - Temperature fluctuation is minimal.
  - Temperature can be maintained between 10 and 50 °C (50 and 110°F) with 20 to 90% RH.
  - No direct heat radiation is present.
  - High levels of electromagnetic interference are not present
  - The unit is not exposed to water.
  - No flammable materials are present.
  - Dust particles are not present in the air.
  - Exposure to ultraviolet rays is minimal.
  - Openings on the rear of the controller are not blocked.
- (3) This unit is suitable for installation in an environment classified as Pollution Degree 2.
- (4) This unit is designated as Installation Category II.
- (5) If the equipment is used in a manner not specified by the manufacturer, the protection provided by the equipment may be impaired.
- (6) A switch or circuit-breaker acting as the disconnect device shall be included in the application or the installation.

**CAUTION**

## Controller Mounting Precautions

- Keep the input circuit wiring as far as possible away from power and ground circuits.
- Keep the units in 10 to 50°C (50 to 110°F) with 20% to 90% relative humidity (RH).  
The controller may need a warm up period to return to operating temperature ranges when below 10°C.
- To prevent electric shock, be sure to turn off the power source and circuit breaker before wiring.
- The power requirements are 100 to 240 VAC, 50/60 Hz, 10 VA max. Do not switch power supplies without first disconnecting the power supply.
- Follow the operating procedures and precautions in the manual to avoid fire, shock, damage to the unit, or injury. Follow the operations and mounting directions indicated in this manual.
- Always create a ground connection where indicated, however do not ground to gas pipes, water pipes, lightning rods, or other potentially hazardous metal objects.
- Do not apply power to the unit until all connections have been made.
- Do not cover the venting holes in the rear of the unit.

## 1.1 SPECIFICATIONS

*Except where noted all specifications apply to operation at 23°C.*

### General

|                        |  |                         |                         |                  |
|------------------------|--|-------------------------|-------------------------|------------------|
| DISPLAY                | Dual 4 digits, red LED, -1999 to 9999  |                         |                         |                  |
|                        | DIN Sizes  | PV Display<br>mm (inch) | SP Display<br>mm (inch) | Weight<br>g (oz) |
|                        | 1/16   | 11.3 (0.45)             | 9.5 (0.37)              | 198 (7.0)        |
|                        | 1/4  | 20.5 (0.81)             | 11.0 (0.43)             | 389 (13.7)       |
| FRONT PANEL            | 1/16 DIN: IP65; 1/4 DIN: IP55  |                         |                         |                  |
| SAMPLING TIME          | 250 ms   |                         |                         |                  |
| OVERRANGE              | Over range PV reads $\alpha\beta r$ , under range PV reads $-\alpha\beta r$  |                         |                         |                  |
| PROGRAMMING<br>METHODS | Four front panel buttons and Modbus  |                         |                         |                  |
| NOISE FILTER           | Programmable from 1 to 120   |                         |                         |                  |
| CALIBRATION            | All ranges are calibrated at the factory   |                         |                         |                  |
| MAX/MIN<br>DISPLAY     | Max/min readings reached by the process are stored until limit reset or until power to the controller is turned off.                             |                         |                         |                  |
| OVER LIMIT<br>TIMER    | Time since the last PV over limit occurrence is stored until the system is reset by the user or until power to the controller is turned off.     |                         |                         |                  |
| PASSWORD               | Programmable password restricts modification of programmed settings  |                         |                         |                  |
| POWER                  | 100-240 VAC, 50/60 HZ, 10 Watts  |                         |                         |                  |
| FUSE                   | Required fuse: UL Recognized, 1 A, 250 V, slow blow  |                         |                         |                  |
| ISOLATION              | 2300 V input-to-output-to-power line;<br>4 kV relay output-to-input/output/power line  |                         |                         |                  |
| ENVIRONMENTAL          | Operating temperature range: 10°C to 50°C (50°F to 110°F)<br>Relative humidity: 20 to 90% non-condensing   |                         |                         |                  |
| MOUNTING               | 1/16 or 1/4 DIN size cutout required<br>Two panel mounting bracket assemblies provided for PD578<br>One one-piece bracket provided for the PD570 |                         |                         |                  |
| WARRANTY               | Three years parts and labor  |                         |                         |                  |

## Process and Temperature Inputs

|                            |   |
|----------------------------|---|
| TEMPERATURE DRIFT          | Refer to accuracy specifications below  |
| DECIMAL POINT              | Up to three decimal places for process inputs:<br>9.999, 99.99, 999.9, or 9999  |
| REAR JUNCTION COMPENSATION | Automatic or off settings for temperature inputs. No user calibration required.   |
| OFFSET ADJUSTMENT          | Four programmable input bias zones  |
| SENSOR BREAK DETECTION     | Open sensor indicated by PV display flashing $5.0Pn$ .<br>Up or down scale, user selectable; relays will follow the up or down scale selection. |
| TRANSMITTER SUPPLY         | 14 to 18 VDC @ 20 mA; available at terminals OUT2 or OUT3, instead of a retransmitting analog output  |

## UNIVERSAL INPUT TYPE AND ACCURACY

|             |  | Temp Range (°C)  | Temp Range (°F)   | Accuracy*   |
|-------------|--|--|---|---|
| Input Type  | Thermocouple   | K1   | -200 to 1370  | > 0°C : ±0.1% FS ±1 digit<br>< 0°C : ±0.2% FS ±1 digit  |
|             |  | K2   | -199.9 to 999.9   |   |
|             |  | J  | -199.9 to 999.9   |   |
|             |  | T  | -199.9 to 400.0   |   |
|             | B  | 0 to 1800  | 32 to 3300  | > 400°C : ±0.15% FS ±1 digit<br>< 400°C : ±5% FS ±1 digit   |
|             | R  | 0 to 1700  | 32 to 3100  | ±0.15% FS ±1 digit  |
|             | S  | 0 to 1700  | 32 to 3100  |   |
|             | E  | -199.9 to 999.9  | -300 to 1800  | > 0°C : ±0.1% FS ±1 digit<br>< 0°C : ±0.2% FS ±1 digit  |
|             | L  | -199.9 to 900.0  | -300 to 1600  |   |
|             | U  | -199.9 to 400.0  | -300 to 750   |   |
| N           | -200 to 1300   | -300 to 2400   | > 0°C : ±0.1% FS ±1 digit<br>< 0°C : ±0.25% FS ±1 digit |   |
| W           | 0 to 2300  | 32 to 4200   | ±0.2% FS ±1 digit                                       |   |
| Platinel II | 0 to 1390  | 32 to 2500   | ±0.1% FS ±1 digit                                       |   |
| RTD         | PtA  | -199.9 to 850.0  | -300 to 1560  | ±0.1% FS ±1 digit**   |
|             | PtB  | -199.9 to 500.0  | -199.9 to 999.9   |   |
|             | PtC  | -19.99 to 99.99  | -4.0 to 212.0   | ±0.2% FS ±1 digit   |
|             | JPtA   | -199.9 to 500.0  | -199.9 to 999.9   | ±0.1% FS ±1 digit**   |
|             | JPtB   | -150.0 to 150.0  | -199.9 to 300.0   |   |
| Process     | 0.4 to 2.0 V<br>1 to 5 V<br>0 to 10 V<br>-10 to 20 mV<br>0 to 100 mV | 0.400 to 2.000<br>1.000 to 5.000<br>0.00 to 10.00<br>-10.00 to 20.00<br>0.0 to 100.0 |   | ±0.1% FS ±1 digit<br>Display range can be scaled between -1999 and 9999.<br><br>4 to 20 mA Input<br>To accept a 4 to 20 mA signal select 0.4 to 2.0 VDC input and connect a 100Ω resistor across the input terminals. |

\*Performance within recommended operating conditions (10 to 50°C, 20 to 90% RH)

\*\*For a range scale of 0 to 100°C: +0.3°C+1 digit, and for a range scale of -100 to 100°C: +0.5°C+1 digit



---

## Relay Outputs

---

|                              |  |
|------------------------------|--|
| RATINGS                      | Out1: 250 VAC @ 3 A or 30 VDC @ 3 A (resistive load)<br>Alarm: 250 VAC @ 1 A or 30 VDC @ 1 A (resistive load)  |
| ELECTRICAL NOISE SUPPRESSION | A suppressor (snubber) should be connected to each relay contact switching inductive loads, to prevent disruption to the microprocessor's operation.<br>Recommended suppressor value: 0.1 $\mu$ F/470 $\Omega$ , 250 VAC (PDX6901)                       |
| DEADBAND                     | For alarm operations, 0-100% of full scale, user selectable  |
| HIGH OR LOW ALARM            | User may program the alarm relay for high or low trip point  |
| DEVIATION ALARM              | User may program the alarm relay for a high, low, or range set point deviation alarm.  |
| RELAY OPERATION              | Out 1, the Limit Control Relay, will activate when the PV exceeds the limit set point. It will remain in this state until the PV no longer exceeds the limit set point and the relay is reset by the user. The alarm relay may be set to any alarm type. |
| TIME DELAY                   | 0 to 99 minutes 59 seconds alarm trip delay for each alarm.  |
| FAIL-SAFE OPERATION          | Programmable<br>Independent for each alarm relay   |
| AUTO INITIALIZATION          | When power is applied to the controller, alarm relays will reflect the state of the input to the controller except standby alarms.   |

---

**Retransmitting Output**

---

|               |  |
|---------------|--|
| OUTPUT RANGE  | Retransmitting: 4 to 20 mA (600 $\Omega$ maximum)    |
| SCALING RANGE | Any display range (see range for the input selected) |
| ACCURACY      | $\pm$ 0.1% of full scale                             |

---

**Serial Communications**

---

|               |   |
|---------------|---|
| PROTOCOLS     | Modbus (ASCII, RTU), PC software,                                   |
| UNIT ADDRESS  | 1 to 99 (Max 31 units connected)                                    |
| BAUD RATE     | 600, 1200, 2400, 4800, 9600, 19200 bps, user selectable             |
| RESPONSE TIME | 0 to 100 ms delay response time<br>10 ms increments user selectable |
| DATA          | 7 or 8 bit user selectable  |
| PARITY        | None, even, or odd  |

---

**Approvals**

---

|                |   |
|----------------|---|
| UL RECOGNIZED  | USA and Canada<br>Process Control Equipment |
| UL FILE NUMBER | E244207                                     |
| CE COMPLIANT   |   |

## 2. Front Panel Buttons and LED Indicators

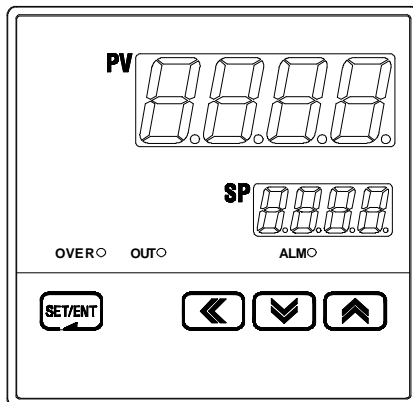

### Control Keys

| KEY                | Function  |
|--------------------|---|
| SET/ENT<br>(ENTER) | Pressing SET/ENT key for at least 3 seconds switches between the operating display and the parameter setting display. This key is used to verify and bypass parameter settings when in the parameter group display. |
| ▲ / ▼<br>(UP/DOWN) | Used to change the value of digits when setting parameters.<br>Used to move between parameter groups.   |
| ◀ (SHIFT)          | Used to move to the next digit when setting parameters.   |
| ◀ RST              | Holding for 3 seconds will re set the limit control latching relay if it is not in an over limit condition. This will reset the time, maximum, and minimum display values.  |

### LED Display

| LED  | Function  |
|------|---|
| OVER | LED activated when the PV value is higher than the limit setting if HI.LO is set to HI.   |
| OUT  | LED activated when the PV value is lower than the limit setting if HI.LO is set to LOW.<br>LED on while the latching relay is de-energized (when in over limit conditions for reverse/failsafe mode). |
| ALM  | LED on when the alarm relay energizes.  |

### 3. Parameter Map

**NOTE**  $P_{LD}$ : Lockout Password  
Use the ▲▼ arrows to enter the password and press the SET/ENT key. The default password is 0.

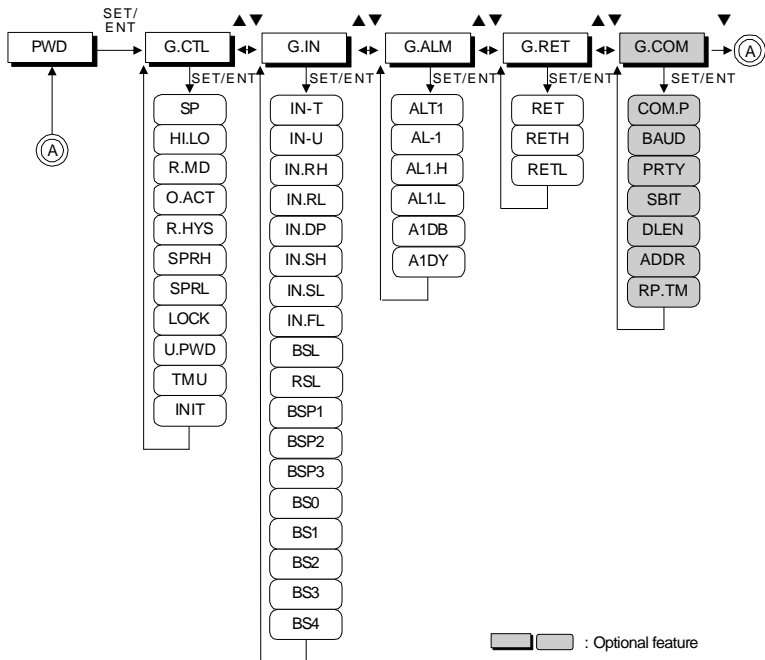

## 4. Operation Flow Chart

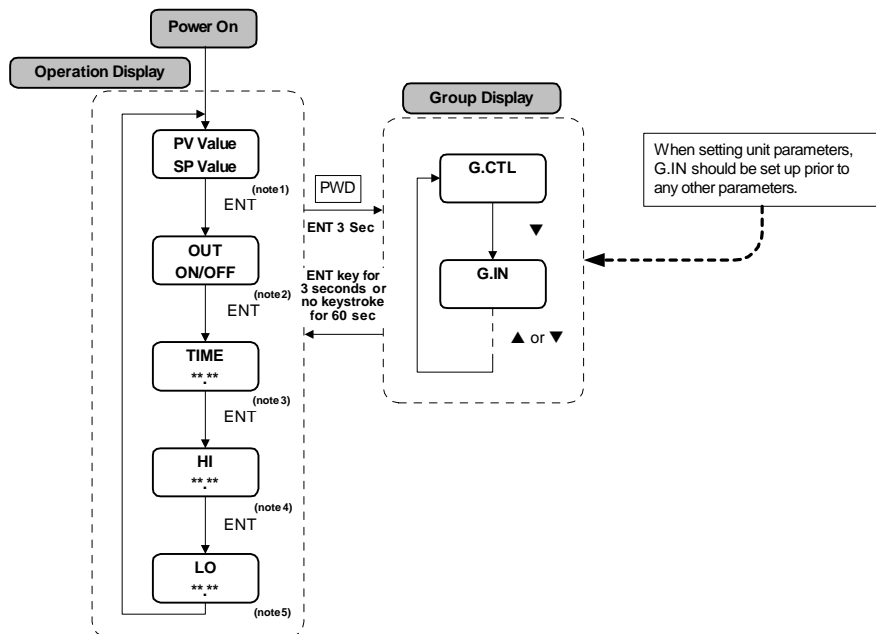

note 1: Initial display at startup.

note 2: Output status for the latching relay.

note 3: The time that has passed since the PV last went over limit.

note 4: Highest PV value. Used only when HILO parameter is set to HIGH.

note 5: Lowest PV. Used only when HILO parameter is set to Low.

## 5. Controller Parameter Setup

### 5.1 Input Group (G.IN)

PV G.IN

Press SET/ENT key to select input group. Press press ▲ or ▼ key to cycle through groups as shown below. (Refer to parameter map in section 3.)

▲▼ PWD ↔ G.CTL ▲▼ G.IN  
 ↑ ↓ G.COM ↔ G.RET ▲▼ G.ALM



Input group parameters should be established first, as changes to the input type may reset other parameter settings in other groups to their default value.

PV in-t

This parameter selects the type of input sensor used. Its default setting is type TC.K1. Refer to the following table showing the type of sensor inputs and select the desired input type.

**Table 1: Universal Input Selection**

*display range : -5% to 105%*

| No. | TYPE        | Temp.Range(°C)    | Temp.Range(°F)  | Group            | DISP |
|-----|-------------|-------------------|-----------------|------------------|------|
| 1   | K1          | -200 to 1370      | -300 to 2500    | Thermocouple     | tcK1 |
| 2   | K2          | -199.9 to 999.9   | 0 to 2300       |                  | tcK2 |
| 3   | J           | -199.9 to 999.9   | -300 to 2300    |                  | tcJ  |
| 4   | E           | -199.9 to 999.9   | -300 to 1800    |                  | tcE  |
| 5   | T           | -199.9 to 400.0   | -300 to 750     |                  | tcT  |
| 6   | R           | 0 to 1700         | 32 to 3100      |                  | tcR  |
| 7   | B           | 0 to 1800         | 32 to 3300      |                  | tcB  |
| 8   | S           | 0 to 1700         | 32 to 3100      |                  | tcS  |
| 9   | L           | -199.9 to 900.0   | -300 to 1600    |                  | tcL  |
| 10  | N           | -200 to 1300      | -300 to 2400    |                  | tcN  |
| 11  | U           | -199.9 to 400.0   | -300 to 750     |                  | tcU  |
| 12  | W           | 0 to 2300         | 32 to 4200      |                  | tcW  |
| 13  | Platinel II | 0 to 1390         | 32 to 2500      | RTD<br>(0.00385) | rtP1 |
| 14  | PtA         | -199.9 to 850.0   | -300 to 1560    |                  | rtA  |
| 15  | PtB         | -199.9 to 500.0   | -199.9 to 999.9 |                  | rtB  |
| 16  | PtC         | -19.99 to 99.99   | -4.0 to 212.0   | RTD<br>(0.00392) | rtC  |
| 17  | JPtA        | -199.9 to 500.0   | -199.9 to 999.9 |                  | JPtA |
| 18  | JPtB        | -150.0 to 150.0   | -199.9 to 300.0 | JPtB             |      |
| 19  | 0.4 to 2.0V | 0.400 to 2.000V   |                 | VDC              | 2V   |
| 20  | 1 to 5V     | 1.000 to 5.000V   |                 |                  | 5V   |
| 21  | 0 to 10V    | 0.00 to 10.00V    |                 |                  | 10V  |
| 22  | -10 to 20mV | -10.00 to 20.00mV |                 | mVDC             | 20mV |
| 23  | 0 to 100mV  | 0.0 to 100.0mV    |                 |                  | 100m |



**4-20 mA Input Selection:**

To accept a 4-20 mA signal, select 0.4 to 2.0 DC input and connect a 100Ω resistor across the input terminals.

|  |  |
|--|--|
|  | <p>This parameter sets the display temperature unit for °C or °F. Its default selection is °C. Refer to Table 1 when changing the temperature unit for the temperature input range.</p>  |
|  | <p>This parameter sets the high limit of the temperature display range (maximum temperature displayed). For mV and V inputs, this sets the value of the high input of the input scale defined in In.SH.</p>  |
|  | <p>This parameter sets the low limit of the temperature display range (minimum temperature displayed). For mV and V inputs, this sets the low input of the input scale defined in In.SL.</p>   |
|  | <p>This parameter sets the position of the decimal point for mV or V inputs. The position of the decimal point can be set as 9999, 999.9, 99.99, or 9.999. Its default set value is 1.</p>   |
|  | <p>This parameter sets the high limit of the mV or V display scale. This value will be displayed when the input is set to the high input established in In.rH. Its default value is 100.0.</p>   |
|  | <p>This parameter sets the low limit of the mV or V display scale. This value will be displayed when the input is set to the low input established in In.rL. Its default value is 0.0.</p>   |
|  | <p>This parameter sets the PV filter for stabilization from electromagnetic noise and interference. This will effect the rate of change of the PV display value. Its default setting is OFF, and can be set from 1 to 120 seconds.</p>   |
|  | <p>This parameter to establishes PV behavior when an open input sensor is detected. When BSL is set to UP, the PV operates as if at the high input range. When BSL is set to DOWN, the PV operates as if at the low input range. Its default setting is UP. In the case of mV or V inputs, the default setting is OFF. An open sensor check is not performed in 10 V, 20 mV, or 100 mV input settings.</p> |
|  | <p>This parameter determines if RJC for thermocouple inputs is used. RJC can be turned on or off. Its default setting is ON.</p>   |
|  | <p>This parameter sets where the PV bias points occur. See Fig 1 and Fig 2 for further information about input bias operation.</p>   |
|  | <p>This parameter sets the bias value at the corresponding bias point input values. These parameters establish the value of the offset at each of the defined BSP1 - BSP3 points. See Fig 1 and Fig 2 for further information about input bias operation.</p>  |

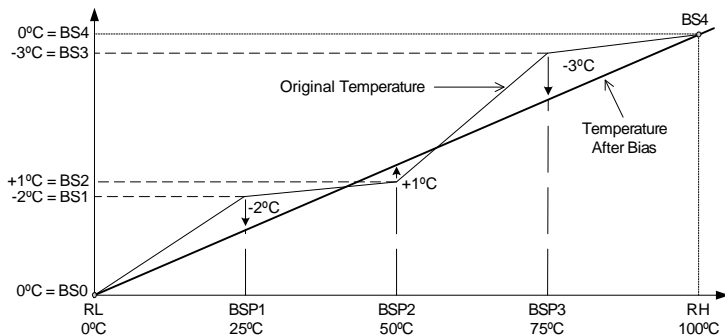
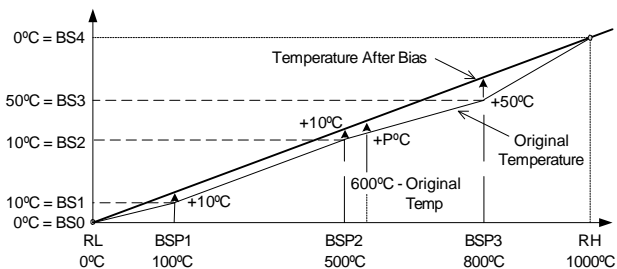

**Fig 1: Temperature Bias**

Example 1: The original temperature is shown within the range of 0°C (Range Low) and 100°C (Range High). Bias points have been used to adjust the displayed temperature as shown in the graph in Fig 1.

To establish this bias, the settings are shown below.

| Temperature Settings to Establish Where the Bias Occurs |      |      |      |       |
|---|------|------|------|-------|
| RL  | BSP1 | BSP2 | BSP3 | RH    |
| 0°C   | 25°C | 50°C | 75°C | 100°C |
| Bias Offset for Each Point                              |      |      |      |       |
| BS0   | BS1  | BS2  | BS3  | BS4   |
| 0°C   | -2°C | +1°C | -3°C | 0°C   |



**Fig 2: Bias Formula Calculation**

Example 2: Temperature Bias Value (BS0 through BS4) = Temperature After Bias - Actual Temperature  
 Display temperature after bias at 600°C actual temperature = P

$$P = 600 + (600 - BPS2) \times \frac{BS3 - BS2}{BSP3 - BSP2} + BS2$$

$$P = 600 + (600 - 500) \times \frac{50 - 10}{800 - 500} + 10 = 623^\circ\text{C Temperature After Bias}$$



## Input Group Parameter Summary







| Display | Parameter               | Setting Range  | Unit | Default      | Remark                 |
|---------|-------------------------|--|------|--------------|------------------------|
| IN-T    | Input Type              | Refer to Table 1: Universal Input Selection                          | ABS  | T.C.K1       |                        |
| IN-U    | Display Unit            | °C / °F  | ABS  | °C           | T/C, RTD               |
| IN.RH   | Max PV Display Range    | Within sensor input range<br>Refer to Table 1<br>INRH > INRL         | AEU  | 1370         |                        |
| IN.RL   | Min PV Display Range    |  | AEU  | -200         |                        |
| IN.DP   | Decimal Point Position  | 0, 1, 2, or 3  | ABS  | 1            | mV, V                  |
| IN.SH   | Max Input Value Scale   | -1999 to 9999<br>INSH > INSL<br>Decimal position determined by IN.DP | ABS  | 100.0        | mV, V                  |
| IN.SL   | Min Input Value Scale   |  |      | 0.0          | mV, V                  |
| IN.FL   | PV Filter               | OFF, 1 to 120  | sec  | OFF          |                        |
| BSL     | Open Sensor Behavior    | OFF, UP, DOWN  | ABS  | UP           | Not Used for VDC input |
| RSL     | RJC Operation           | ON, OFF  | ABS  | ON           | Only Used for TC input |
| BSP1    | Reference Bias Point 1  | AEU (0.0 to 100.0%),<br>RL≤BSP1≤BSP2≤BSP3≤RH                         | AEU  | AEU (100.0%) |                        |
| BSP2    | Reference Bias Point 2  | AEU (0.0 to 100.0%),<br>RL≤BSP1≤BSP2≤BSP3≤RH                         | AEU  | AEU (100.0%) |                        |
| BSP3    | Reference Bias Point 3  | AEU (0.0 to 100.0%),<br>RL≤BSP1≤BSP2≤BSP3≤RH                         | AEU  | AEU (100.0%) |                        |
| BS0     | Bias Value for RL Point | GEU (-100.0 to 100.0%)   | GEU  | 0            |                        |
| BS1     | Bias Value at BSP1      | GEU (-100.0 to 100.0%)   | GEU  | 0            |                        |
| BS2     | Bias Value at BSP2      | GEU (-100.0 to 100.0%)   | GEU  | 0            |                        |
| BS3     | Bias Value at BSP3      | GEU (-100.0 to 100.0%)   | GEU  | 0            |                        |
| BS4     | Bias Value at RH        | GEU (-100.0 to 100.0%)   | GEU  | 0            |                        |

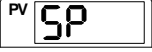
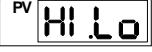
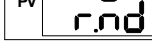

There are two types of engineering units values used in the setting of parameters, absolute engineering units (AEU) and general engineering units (GEU). An AEU parameter is set using an absolute value engineering unit that represents a specific point, such as a specific temperature or voltage level. An GEU parameter is set using engineering units, however it is a general value, and not tied to any input or output level.

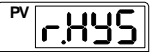
For example: When establishing input bias, parameter BSP1 sets the specific PV value where bias point one will occur. This parameter has a unit designation of AEU. BS1, the amount of offset at BSP1 is set in engineering units, however this parameter occurs at whatever BSP1 is set to, and therefore does not have an absolute setting related to any input or output, it is just the amount of offset at where BSP1 occurs. While one is related to an absolute input value, and the other stand alone value, both are set as engineering units, such as BSP1 set as 100°C and BS1 set as 3°C.

## 5.2 Control Group (G.CTL)

|   |   |
|---|---|
|    | <p>Press SET/ENT key to select control group. (Refer to parameter map in section 3.)</p> <pre>       PWD  ▲▼ ↔ G.CTL ▲▼ ↔ G.IN       ▲   ▲   ▲   ▲   ▲       ▼   ▲   ▼   ▲   ▼       G.COM ↔ G.RET ↔ G.ALM       ▲   ▲   ▲   ▲   ▲     </pre>   |
|    | <p>This parameter establishes the set point for limit operation. This is the value set as the operating limit that will trigger the latching limit control relay. The parameter HI.LO sets if this is a high limit or a low limit.</p>  |
|    | <p>This parameter established the set point as a high or low limit value. If set as a high limit, the unit will consider the input beyond the set limit when PV &gt; SP. If set as a low limit, the unit will consider the input beyond the set limit when PV &lt; SP.</p>  |
|    | <p>This parameter determines the status of the latching relay (OUT1) when the unit is turned on. If R.MD is set as ON, the output condition will be a function the PV and SP as normal. If OFF, the output will enter over limit condition until reset. To set the condition of the relay in normal and over limit conditions, refer to parameter O.ACT below.</p>        |
|    | <p>This parameter sets the operation for the limit control latching relay (OUT1). In reverse (failsafe) operation, the control relay is energized during normal conditions. In forward operation, the control relay is energized during over limit conditions. The default setting is REV. See Fig 3 and 4 for an illustration showing reverse and forward operation.</p> |
|    | <p>This parameter sets the hysteresis for the limit control. When returned within the limit range after being over the set limit, this is an additional amount below the limit that the PV must reach before the latching relay can be reset and the OVER LED turns off.</p>  |
|    | <p>This parameter sets a high limit on what the set points can be programmed or changed to. This value may reset if the type of input is changed, or if parameter IN.RH or IN.RL (IN.SH or IN.SL if input type is mV or V) is changed.</p>  |
|    | <p>This parameter sets a low limit on what the set points can be programmed or changed to. This value may reset if the type of input is changed, or if parameter IN.RH or IN.RL (IN.SH or IN.SL if input type is mV or V) are changed.</p>  |
|   | <p>Turning ON this parameter locks all other settings from being changed. This applies to the operation display functions, such as changing the set point, as well as setting group parameters. The default setting is OFF.</p>   |
|  | <p>This parameter establishes the password for the controller. This password must be entered at the PWD screen before accessing the control group (G.CTL) or it will not access the setting groups after the PWD prompt. The default setting is "0". See the parameter map in section 3 for the location of the PWD prompt in the group menus.</p>                        |



Be sure not to forget the password once it has been set. If the password is forgotten, contact technical support as listed on the back of this manual.

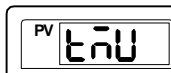

This parameter sets the time units the controller uses for parameters with time components. This can be set to the format of HH.MM (hours.minutes) or MM.SS (minutes.seconds). Its default setting is HH.MM.

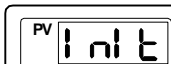

This parameter resets most parameters to their factory settings. To reset the controller, set this parameter to ON. After reset, it will return to the OFF setting.



Most parameters will be reset to their default settings when the controller is initialized. Note the current settings before this is done so they can easily be restored after controller initialization.

## 5-2-1 Limit Control Features and Operations

### 5-2-1-1 Operation of Limit Functions when O.ACT = REV, HI.LO = HIGH, R.MD = OFF

The following illustration shows how each aspect of the limit control functions behave under over limit circumstances.

1. Power supplied to the controller. The OUT LED turns on.
2. The PV surpasses the SP. The OUT LED turns on. The OVER LED turns on. The latching limit control relay energizes. The time begins being recorded.
3. The PV falls below the limit and hysteresis levels. The OVER LED turns off. The time count stops.
4. The PV surpasses the SP. The OVER LED turns on. The time count resets and begins again.
5. The PV falls below the limit and hysteresis levels. the OVER LED turns off. The time count stops.

When the reset button is pressed for 3 seconds, and the PV is below the SP, the OUT LED will turn off, and the limit control relay will energize.

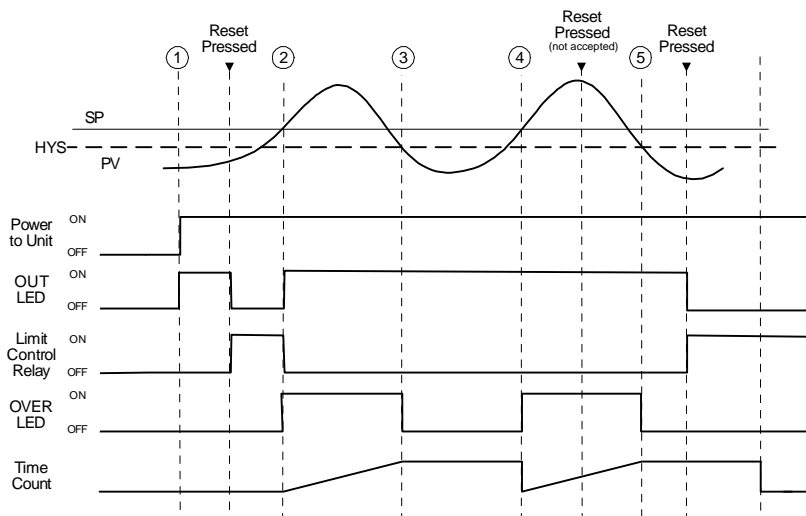

Fig 3: Operation of Limit Functions with O.ACT set to REV

Time Reset by User

### 5-2-1-2 Operation of Limit Functions when O.ACT = FWD, HI.LO = HIGH, R.MD= OFF

The following illustration shows how each aspect of the limit control functions behave under over limit circumstances when O.ACT is set to FWD operation.

1. Power supplied to the controller. The limit control relay energizes.
2. The PV surpasses the SP. The OUT LED turns off. the OVER LED turns on. The latching limit control relay energizes. The time begins being recorded.
3. The PV falls below the limit and hysteresis levels. The OVER LED turns off. The time count stops.
4. The PV surpasses the SP. The OVER LED turns on. The time count resets and begins again.
5. The PV falls below the limit and hysteresis levels. the OVER LED turns off. The time count stops.

When the reset button is pressed for 3 seconds, and the PV is below the SP, the OUT LED will turn on, and the limit control relay will turn off.

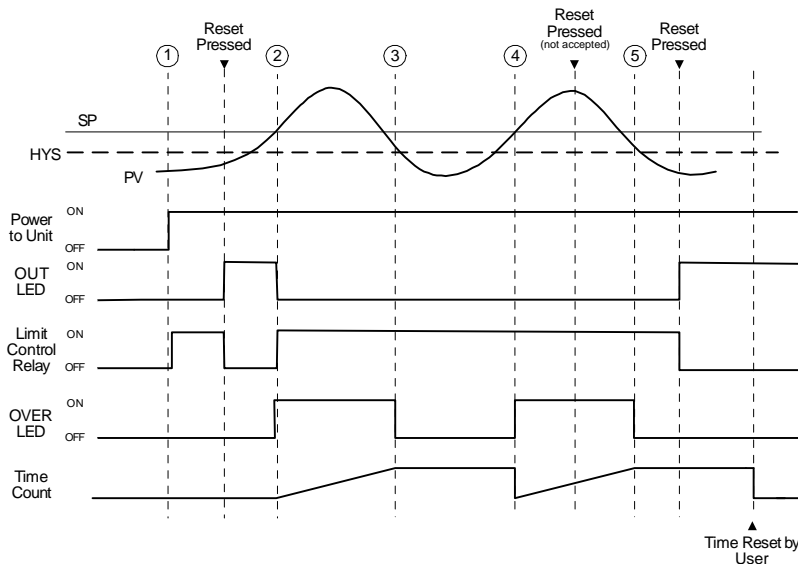

Fig 4: Operation of Limit Functions with O.ACT set to FWD

### 5-2-2 Limit Status Display and Reset Functions

The condition of the output can be seen by pressing the SET/ENT as shown in the Operation Flow Chart in section 4. The output status display refers to the condition of the limit control relay output.

The output display has two conditions, OFF and ON.

In the OFF condition:

Normally Closed (NC) Terminal: Closed

Normally Open (NO) Terminal: Open

In the ON condition:

Normally Closed (NC) Terminal: OPEN

Normally Open (NO) Terminal: CLOSED

To reset the limit control relay after the PV has gone over limit, it must be within the set point limit. Pressing the reset button for 3 seconds will return the limit control relay to OFF.

In the following illustration of output operation, H.L.O is set to HIGH, O.ACT set to REV, and R.MD set to OFF.

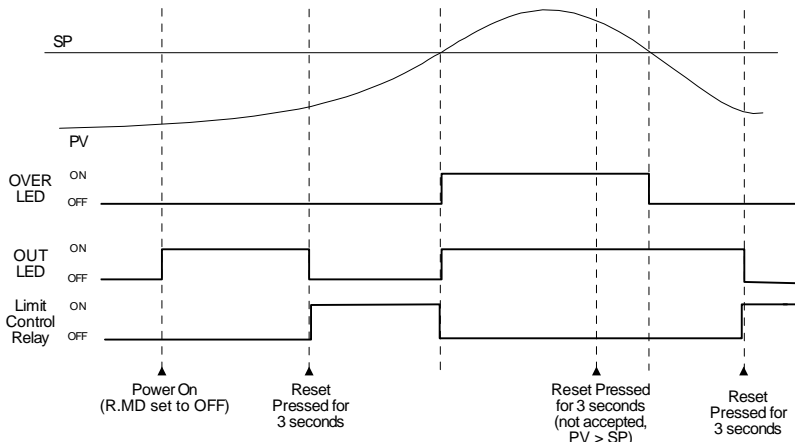

Fig 5: Example of Limit Control Relay Operation and Reset Function

### 5-2-3 Over Limit Timer

The time the PV has been over the SP limit is displayed in the operation display as shown in the Operation Flow Chart in section 4.

When the PV exceeds the SP value, the over limit timer begins operation. This will record the time that the PV is over the SP. If the PV returns to within the SP limit, the timer will stop. If following this the PV once again exceeds the SP, the timer will reset, and begin timing again.

The time passed cannot be reset while the PV is over the SP limit. If the PV is under the SP limit, the time count can be reset with the reset key.

The timer display range is:

0.0 - 999.9 min (HH.MM)

0.0 - 999.9 sec (MM.SS)

### 5-2-4 Maximum or Minimum PV Value Display







The maximum or minimum PV values are displayed in the operation display. Refer to the Operation Flow Chart in section 4.

If set for a high limit with H.L.O set to HIGH, the maximum PV value will be displayed. If set for a low limit with H.L.O set to LOW, the minimum PV value will be displayed. This value can be reset with the reset key while in the display screen.

**Control Group Parameter Summary**

| Display | Parameter                             | Setting Range       | Unit | Default      | Remark |
|---------|---------------------------------------|---------------------|------|--------------|--------|
| SP      | Limit Set Point                       | AEU (0.0 to 100.0%) | AEU  | AEU (0.0%)   |        |
| HI.LO   | High or Low Limit Operation Selection | HI, LO              | ABS  | HI           |        |
| R.MD    | Restart Relay Mode                    | ON, OFF             | ABS  | OFF          |        |
| O.ACT   | Reverse and Forward Operation         | REV, FWD            | ABS  | REV          |        |
| R.HYS   | Hysteresis Value                      | GEU (0.0 to 10.0%)  | GEU  | GEU (0.5%)   |        |
| SPRH    | Set Point Range High                  | AEU (0.0 to 100.0%) | AEU  | AEU (100.0%) |        |
| SPRL    | Set Point Range Low                   | AEU (0.0 to 100.0%) | AEU  | AEU (0.0%)   |        |
| LOCK    | Parameter Lock                        | OFF, ON             | ABS  | OFF          |        |
| U.PWD   | User Password                         | 0 to 9999           | ABS  | 0            |        |
| TMU     | Time Unit                             | HH.MM, MM.SS        | ABS  | HH.MM        |        |
| INIT    | Factory Initialization                | OFF, ON             | ABS  | OFF          |        |

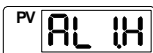
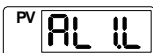
## 5.3 Alarm Group (G.ALM)

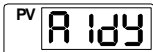
|   |   |
|---|---|
|  | <p>Press SET/ENT key to select alarm group. (Refer to parameter map in section 3.)</p> <div style="text-align: center;">  </div> |
|  | <p>The parameter to set the type of alarm to be set for alarm 1. The types of alarms selectable are shown in Table 3: Alarm Selection.</p>  |
|  | <p>The parameter to set the alarm trigger point for the alarm set in ALt1. This parameter displays if a high, low, or high and low limit alarm was selected for ALt1.</p>   |
|  | <p>This establishes the high deviation range to trigger the alarm of deviation. This parameter displays if a deviation alarm was selected in ALt1.</p>  |
|  | <p>This establishes the low deviation range to trigger the alarm of deviation. This parameter displays if a deviation alarm was selected in ALt1.</p>   |
|  | <p>The parameter to set the dead band (Hysteresis) of alarm 1.</p>  |
|  | <p>The parameter to set the delay time before of alarm 1 is triggered.</p>  |

 **Alarm Types and LED Display**

SP 

- **S** indicates standby operation
- **F** for forward operation
- **r** for reverse (failsafe) operation
- Decimal point always displayed
- **H** indicates a high alarm
- **L** indicates a low alarm
- **o** for outside range of deviation band
- **I** for inside range of deviation band
- **A** indicates an absolute value alarm
- **d** indicates a deviation alarm

**Alarm Output Settings:**

- Forward: Relay energized in alarm condition
- Reverse: Failsafe operation. Relay energized during normal operating conditions

**Standby Operation:**

- The alarm will not trigger if the alarm condition occurs during the following activities...
- during power-up
  - the set point is changed
  - the type of alarm is changed

Table 3: Alarm Selection

| No. | Alarm Type  | Operation |     | Standby |     | Display Data |
|-----|---|-----------|-----|---------|-----|--------------|
|     |   | For       | Rev | On      | Off |              |
| 1   | Absolute Value High Limit Alarm                       | ✓         |     | ✓       |     | AH.F         |
| 2   | Absolute Value Low Limit Alarm                        | ✓         |     | ✓       |     | AL.F         |
| 3   | High Limit Deviation Alarm                            | ✓         |     | ✓       |     | DH.F         |
| 4   | Low Limit Deviation Alarm                             | ✓         |     | ✓       |     | DL.F         |
| 5   | High Limit Deviation Alarm                            |           | ✓   | ✓       |     | DH.R         |
| 6   | Low Limit Deviation Alarm                             |           | ✓   | ✓       |     | DL.R         |
| 7   | High and Low Limit Deviation Alarm                    | ✓         |     | ✓       |     | DO.F         |
| 8   | High and Low Limit Range Deviation Alarm              | ✓         |     | ✓       |     | DI.F         |
| 9   | Absolute Value High Limit Alarm                       |           | ✓   | ✓       |     | AH.R         |
| 10  | Absolute Value Low Limit Alarm                        |           | ✓   | ✓       |     | AL.R         |
| 11  | Absolute Value High Limit Alarm with Standby          | ✓         |     |         | ✓   | AH.FS        |
| 12  | Absolute Value Low Limit Alarm with Standby           | ✓         |     |         | ✓   | AL.FS        |
| 13  | High Limit Deviation Alarm with Standby               | ✓         |     |         | ✓   | DH.FS        |
| 14  | Low Limit Deviation Alarm with Standby                | ✓         |     |         | ✓   | DL.FS        |
| 15  | High Limit Deviation Alarm with Standby               |           | ✓   |         | ✓   | DH.RS        |
| 16  | Low Limit Deviation Alarm with Standby                |           | ✓   |         | ✓   | DL.RS        |
| 17  | High and Low Limit Deviation Alarm with Standby       | ✓         |     |         | ✓   | DO.FS        |
| 18  | High and Low Limit Range Deviation Alarm with Standby | ✓         |     |         | ✓   | DI.FS        |
| 19  | Absolute Value High Limit Alarm with Standby          |           | ✓   |         | ✓   | AH.RS        |
| 20  | Absolute Value Low Limit Alarm with Standby           |           | ✓   |         | ✓   | AL.RS        |

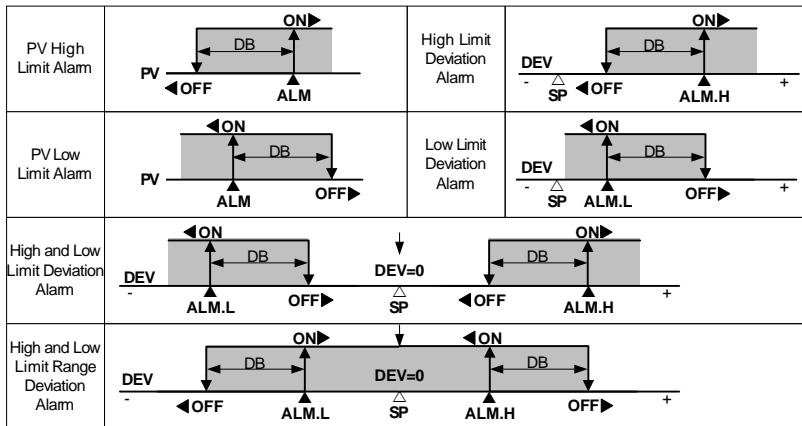

Fig 6: Alarm Operation



**Alarm Group Parameter Summary**

| Display | Parameter                       | Setting Range                     | Unit  | Default     | Remark               |
|---------|---------------------------------|-----------------------------------|-------|-------------|----------------------|
| ALT1    | Alarm Type 1                    | Refer to Table 3: Alarm Selection | ABS   | AH.F        |                      |
| AL-1    | Set value of ALT1               | AEU (-100.0 to 100.0%)            | AEU   | EU (100.0%) | Absolute Value Alarm |
| AL1.H   | High Deviation Limit of Alarm 1 | GEU (-100.0 to 100.0%)            | GEU   | EUS (0.0%)  | Deviation Alarm      |
| AL1.L   | Low Deviation Limit of Alarm 1  | GEU (-100.0 to 100.0%)            | GEU   | EUS (0.0%)  | Deviation Alarm      |
| A1DB    | Alarm 1 DB                      | GEU (0.0 to 100.0%)               | GEU   | EUS (0.5%)  |                      |
| A1DY    | Delay Time of Alarm 1           | 0.00 to 99.59                     | MM.SS | 0.00        |                      |

## 5.4 Retransmission Group (G.RET)

PV G r Et

Press SET/ENT key to select retransmission group. (Refer to parameter map.)

PV r Et

This parameter sets the type of retransmission mode to use. The setting options are PV, SP, and LPS. See notes below for an explanation of the retransmission types. The default setting is PV.

PV r EtH  
  
 PV r EtL

These parameters are used to scale the retransmitting output. They set the high and low limits for the retransmission output scale, as shown below. The retransmitting outputs will transmit 4 mA at the low limit (RETL) and 20 mA at the high limit (RETH) values. These limits are used when the retransmission type is set to PV or SP.

**PV and SP Type Retransmission Scale**

PV type retransmits based on the input value, SP retransmits based on the set point value.

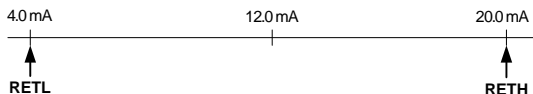







**LPS Type Retransmission**

LPS (Loop Power Supply) retransmitting outputs will transmit a 14-18 VDC @ 20 mA power supply output.

**Retransmission Group Parameter Summary**

| Display | Parameter            | Setting Range  | Unit | Default | Remark |
|---------|----------------------|--|------|---------|--------|
| RET     | Select Ret Type      | PV, SP, LPS  | ABS  | PV      |        |
| RETH    | Ret Scale High Limit | T/C, RTD: INRH to INRL<br>mV, V: INSH to INSL<br>RETH > RETL | AEU  | INRH    |        |
| RETL    | Ret Scale Low Limit  |  | AEU  | INRL    |        |

## 5.5 Communication Group (G.COM)

|   |   |
|---|---|
|  | <p>Press SET/ENT key to select communication group. (Refer to parameter map.)</p>    |
|  | <p>The parameter to select the type of communication protocol to be used.</p>   |
|  | <p>The parameter to set the communication speed (baud rate).<br/>The baud rate can be set at 600 to 19200 bps (bytes per second).<br/>The default setting is for 9600 bps.</p>  |
|  | <p>The parameter to set communication parity.<br/>This can be set to NONE, EVEN, or ODD.<br/>The default setting is NONE.</p>   |
|  | <p>The parameter to set the communication stop bit.<br/>This can be set as 1 or 2.<br/>It is initially set as 1.</p>  |
|  | <p>The parameter to set the communication data length.<br/>This can be set to 7 or 8. The default setting is 8.<br/>This parameter is not displayed when the communication protocol (COM.P) is set for MODBUS ASCII or RTU.</p>   |
|  | <p>The parameter to set the communication address for the controller.<br/>This can be set as 1 to 99 pcs address.<br/>Its default setting is 1.</p>   |
|  | <p>The parameter to set communication response time.<br/>The RP.TM is the delay to return data to the upper level device after processing commands received from the upper level device.<br/>The setting RP.TM is based on the number of 10 ms intervals to delay (example: a setting of 2 will result in a 20 ms delay). If RP.TM is set to 0 it will immediately return a response once the command processing is complete.</p> |

**Communication Group Parameter Summary**

| Display | Parameter              | Setting Range                             | Unit | Default | Remark |
|---------|------------------------|---|------|---------|--------|
| COM.P   | Communication Protocol | PCC0, PCC1, Modbus ASCII, Modbus RTU      | ABS  | PCC0    | Option |
| BAUD    | Baud Rate              | 600, 1200, 2400, 4800, 9600, 19200        | ABS  | 9600    | Option |
| PRTY    | Parity                 | None, Even, Odd                           | ABS  | None    | Option |
| SBIT    | Stop Bit               | 1, 2                                      | ABS  | 1       | Option |
| DLEN    | Data Length            | 7, 8 (not used when set for MODBUS)       | ABS  | 8       | Option |
| ADDR    | Address                | 1 to 99 (maximum of 31 connected at once) | ABS  | 1       | Option |
| RP.TM   | Response Time          | 0 to 10 (number of 10ms intervals)        | ABS  | 0       | Option |

## 6. Error Display and Correction

| Error Message       | Error Incident        | Action Needed    |
|---------------------|-----------------------|------------------|
| E.SYS               | EEPROM, Data Loss     | Needs Repair     |
| E.RJC               | RJC Sensor Failure    | Needs Repair     |
| SP Decimal Flashing | Communication Failure | Check Comm Cable |
| S.OPN               | Open Sensor Detected  | Check Sensor     |

## 7. Installation

### 7.1 Dimensions and Panel Cutouts

PD578

1/4 DIN

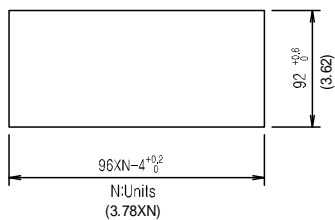
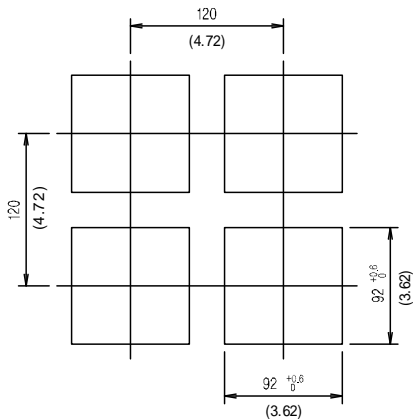
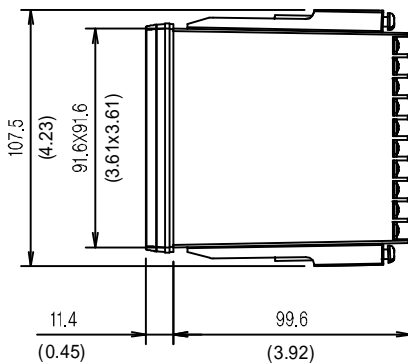
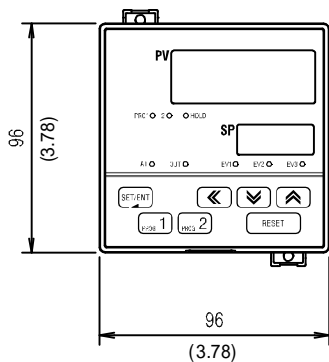

Units: mm  
(inch) - for reference only

**PD570**

**1/16 DIN**

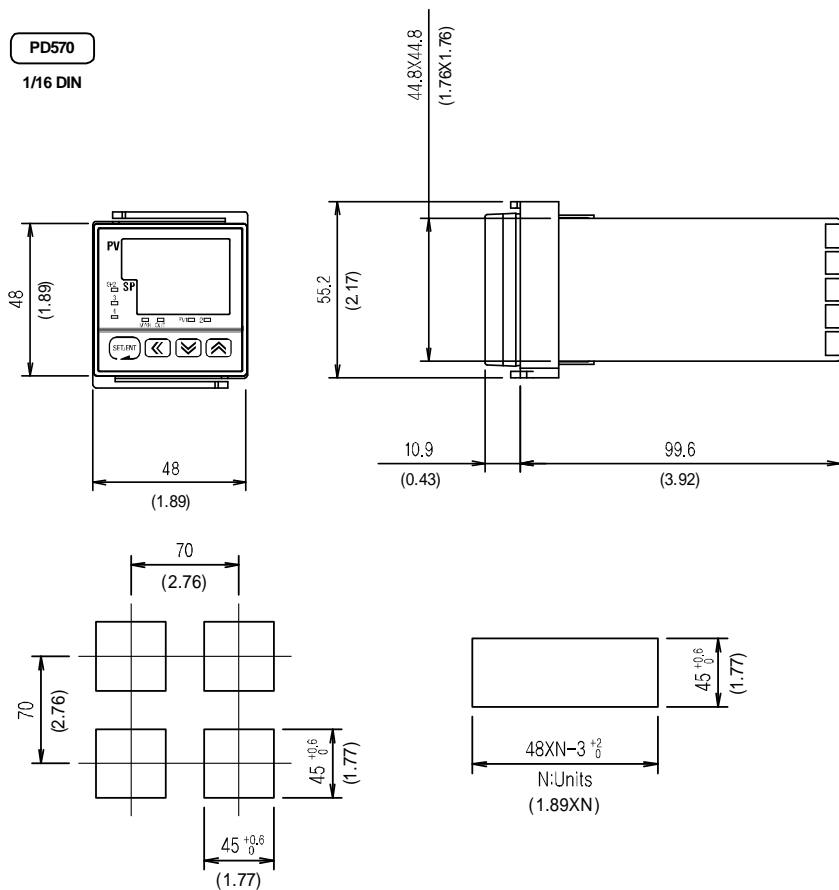

Units: mm  
(inch) - for reference only

## 7.2 Panel Mounting

PD578

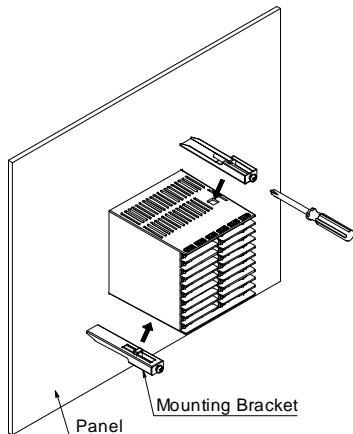

PD570

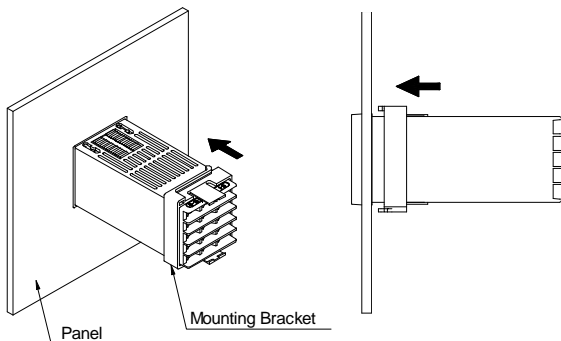

### Installation Steps

1. Cut the mounting panel. (Refer to 7.1 Dimensions and Panel Cutouts)
2. Insert the controller through the front of the panel rear terminals first.
3. On applicable models, attach the right and left mounting bracket and secure it to the panel.
4. On 1/16 DIN controller models, slide the mounting bracket onto the back of the controller as shown, and slide it forward on the controller until the bracket locks in place, and the controller is secure.



Do not excessively tighten the mounting bracket screws. Excessive tightening may lead to controller or panel damage.



### 7.3 Power Cable Specification

Make power connections using 0.9 to 2.0 mm<sup>2</sup> or 16 AWG vinyl insulated wire. (Voltage rating of 300 VAC)

### 7.4 Terminal Specification

Use M3.5 screw-compatible crimp on terminals with insulating sleeve as shown below.

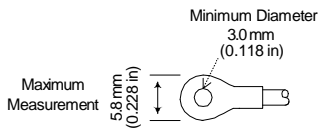

Note: Inches for reference only.

Use copper conductors only if the terminal is for connection to copper wire only.



Always turn off the source circuit breaker and check to ensure the power is off to the controller through the use of a tester prior to working on the wiring terminals.

- Never touch the terminals in the rear panel when power is supplied to the controller.
- Be sure to turn off the electric power before wiring any terminals.



Bind the wires connected to the controller terminals neatly together in order to prevent electromagnetic interference.

### 7.5 Terminal Assignment, Connections, and Ratings

**PD578**

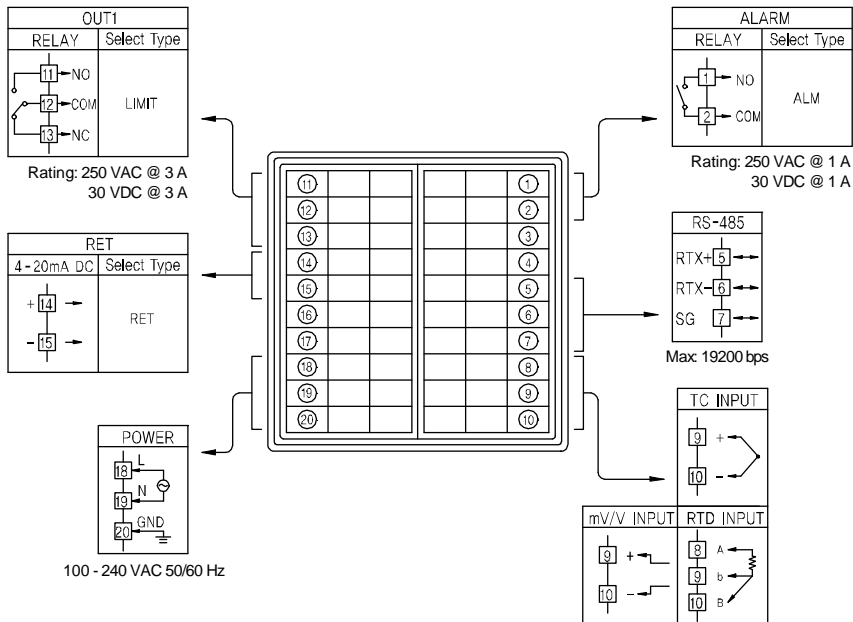

**PD570**

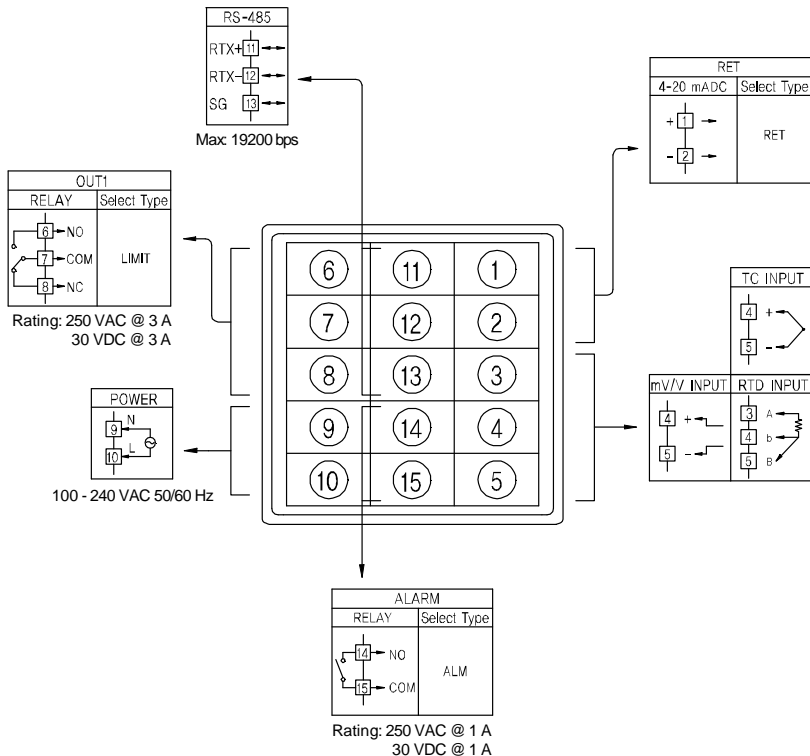

## 7.6 Grounding and Power Cable Connection

- Use a thick grounding cable of at least 2 mm<sup>2</sup> or 14 AWG and shorter than 20 m (approximately 22 ft) for class-3 grounding or better with a grounding resistance of less than 100 Ω.
- Be sure to ground from the grounding terminal to an independent grounding point. (1 point grounding)
- Use 0.9 to 2.0 mm<sup>2</sup> or 16 AWG vinyl insulated wire (Voltage rating 300VAC) or thicker for power cable connection.

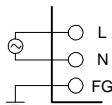

Be sure to connect L (Hot), N (neutral), and GND (ground) as indicated. Failure to wire the power and ground as indicated could result in damage to the controller.



To prevent electric shock, be sure to turn off power to the Nova Controller and the source circuit breaker before wiring.



- Be sure to connect to correct polarities. Connecting to a wrong polarity may cause damage or malfunction.
- Use shielded wires and ground the shielding to an independent grounding point.
- Keep the input signal and output wiring as far as possible away from the power and ground circuit.
- Use a wire with low conductive resistance and no three-wire resistance differential.

## 7.7 Signal Input Connection

(1) RTD Input

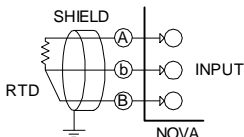

(2) DC Voltage Input

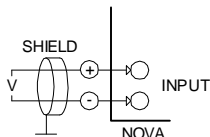

(3) DC Current Input

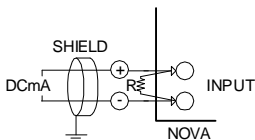

To accept a 4-20 mA signal, select 0.4 to 2.0 VDC input and connect a 100 Ω resistor across the input terminals as shown.

## 7.8 Retransmission Output Connection (RET)



To prevent electric shock, be sure to turn off power to the Nova Controller and the source circuit breaker before wiring.



- Be sure to connect to correct polarities. Connecting to a wrong polarity may cause a controller malfunction.
- Use shielded wires for the wiring and connect independently to ground (1 point grounding).

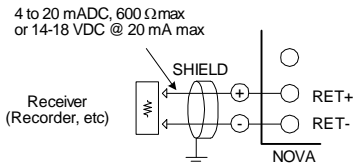

To prevent electric shock, be sure to turn off power to the Nova Controller and the source circuit breaker before wiring.

## 7.9 Relay Output Connection (RELAY)

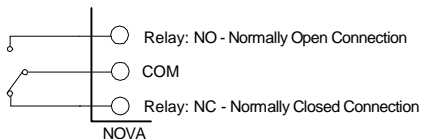

To prevent electric shock, be sure to turn off power to the Nova Controller and the source circuit breaker before wiring.

## 7.10 Use of an External Relay

### Switching Inductive Loads

When using switching inductive loads, the use of RC networks (snubbers) for AC loads or diodes for DC loads is recommended to prevent disrupting the microprocessor's operation. The suppressors also prolong the life of the relay contacts. Suppression can be obtained with resistor-capacitor (RC) networks or diodes assembled by the user or purchased as complete assemblies.

For AC loads, choose R and C as follows:

R: 0.5 to 1  $\Omega$  for each volt across the contact

C: 0.5 to 1  $\mu$ F for each amp through closed contacts

#### Notes:

1. Use capacitors rated for 250 VAC.
2. RC networks may affect load release time of solenoid loads. Check to confirm proper operation.
3. RC networks are available from Precision Digital and should be applied to each relay contact switching an inductive load. Part number: PDX6901.



If the load inductance is over the controller specifications, the output may need a RC filter (snubber) or diode to properly handle frequent relay switching operations.

#### (1) DC External Relay

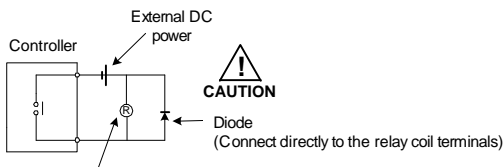

**CAUTION** Relay (Verify relay coil ratings are less than the voltage and current ratings of the relay contacts of the controller)

#### (2) AC External Relay

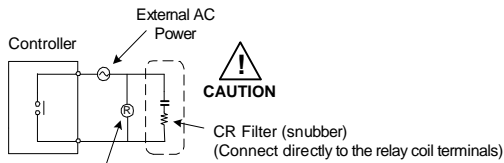

**CAUTION** Relay (Verify relay coil ratings are less than the voltage and current ratings of the relay contacts of the controller)

## 7.11 Communication Wiring (RS-485)

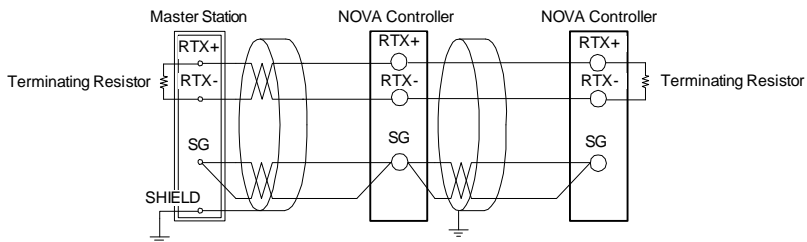

- Up to 31 slave controllers (Nova series controllers equipped with the RS-485 serial communication option) can be connected.
- Be sure to connect terminating resistors ( $220\ \Omega$ , 1/4 W) to slave and master controllers at communication channel ends as shown above.



To prevent electric shock, be sure to turn off power to the Nova Controller and the source circuit breaker before wiring.

**Table of D-Registers:**

The following data registers are used to direct the US1 and US2 commands or for Modbus communication.

| NO. | PROCESS   | FUNCTION | SET POINT | SIGNAL | ALARM | PID | IN/OUT |
|-----|-----------|----------|-----------|--------|-------|-----|--------|
|     | 0         | 100      | 200       | 300    | 400   | 500 | 600    |
| 0   |           |          |           |        |       |     |        |
| 1   | NPV       |          | SP        |        | ALT1  |     | IN-T   |
| 2   | NSP       |          |           |        |       |     | INT-U  |
| 3   |           |          |           |        |       |     | IN.RH  |
| 4   |           |          |           |        |       |     | IN.RL  |
| 5   |           |          |           |        |       |     | IN.DP  |
| 6   |           |          |           |        | AL-1  |     | IN.SH  |
| 7   |           |          |           |        |       |     | IN.SL  |
| 8   |           |          |           |        |       |     | IN.FL  |
| 9   |           |          |           |        |       |     | BSL    |
| 10  | NOWSTS    |          |           |        |       |     | RSL    |
| 11  |           |          | SPRH      |        | A1DB  |     | BSP1   |
| 12  |           |          | SPRL      |        |       |     | BSP2   |
| 13  |           |          |           |        |       |     | BSP3   |
| 14  | ALSTS     |          | TMU       |        |       |     |        |
| 15  |           |          |           |        |       |     | BS0    |
| 16  |           |          |           |        | A1DY  |     | BS1    |
| 17  |           |          |           |        |       |     | BS2    |
| 18  |           |          |           |        |       |     | BS3    |
| 19  |           |          |           |        |       |     | BS4    |
| 20  |           |          |           |        |       |     |        |
| 21  |           |          |           |        | AL1.H |     |        |
| 22  |           |          |           |        |       |     |        |
| 23  |           |          |           |        |       |     |        |
| 24  |           |          |           |        |       |     |        |
| 25  |           |          |           |        |       |     |        |
| 26  |           |          |           |        | AL1.L |     |        |
| 27  |           |          |           |        |       |     |        |
| 28  |           |          |           |        |       |     |        |
| 29  |           |          |           |        |       |     |        |
| 30  |           |          |           |        |       |     |        |
| 31  |           |          |           |        |       |     |        |
| 32  |           |          |           |        |       |     |        |
| 33  |           |          |           |        |       |     |        |
| 34  |           |          |           |        |       |     |        |
| 35  |           |          |           |        |       |     |        |
| 36  |           |          |           |        |       |     | O.ACT  |
| 37  |           | LOCK     |           |        |       |     |        |
| 38  | HI.VALUE  |          |           |        |       |     |        |
| 39  | LO.VALUE  |          |           |        |       |     |        |
| 40  | KEEP.TIME |          |           |        |       |     |        |
| 41  |           | HI.LO    |           |        |       |     |        |
| 42  |           | R.MD     |           |        |       |     |        |
| 43  |           |          |           |        |       |     |        |



| NO. | PROCESS | FUNCTION | SET POINT | SIGNAL | ALARM | PID | IN/OUT |
|-----|---------|----------|-----------|--------|-------|-----|--------|
|     | 0       | 100      | 200       | 300    | 400   | 500 | 600    |
| 44  |         |          |           |        |       |     |        |
| 45  |         |          |           |        |       |     | HYS    |
| 46  |         |          |           |        |       |     |        |
| 47  |         |          |           |        |       |     |        |
| 48  |         |          |           |        |       |     |        |
| 49  |         |          |           |        |       |     |        |
| 50  |         |          |           |        |       |     |        |
| 51  |         |          |           |        |       |     | RET    |
| 52  |         |          |           |        |       |     | RETH   |
| 53  | U       |          |           |        |       |     | RETL   |
| 54  | s       |          |           |        |       |     |        |
| 55  | e       |          |           |        |       |     |        |
| 56  | r       |          |           |        |       |     |        |
| 57  |         |          |           |        |       |     |        |
| 58  | A       |          |           |        |       |     |        |
| 59  | r       |          |           |        |       |     |        |
| 60  | e       |          |           |        |       |     |        |
| 61  | a       |          |           |        |       |     | COM.P  |
| 62  |         |          |           |        |       |     | BAUD   |
| 63  |         |          |           |        |       |     | PRTY   |
| 64  |         |          |           |        |       |     | SBIT   |
| 65  |         |          |           |        |       |     | DLEN   |
| 66  |         |          |           |        |       |     | ADDR   |
| 67  |         |          |           |        |       |     | RP.TM  |
| 68  |         |          |           |        |       |     |        |
| 69  |         |          |           |        |       |     |        |
| 70  |         |          |           |        |       |     |        |
| 71  |         |          |           |        |       |     |        |
| 72  |         |          |           |        |       |     |        |
| 73  |         |          |           |        |       |     |        |
| 74  |         |          |           |        |       |     |        |
| 75  |         |          |           |        |       |     |        |
| 76  |         |          |           |        |       |     |        |
| 77  |         |          |           |        |       |     |        |
| 78  |         |          |           |        |       |     |        |
| 79  |         |          |           |        |       |     |        |
| 80  |         |          |           |        |       |     |        |
| 81  |         |          |           |        |       |     |        |
| 82  |         |          |           |        |       |     |        |
| 83  |         |          |           |        |       |     |        |
| 84  |         |          |           |        |       |     |        |
| 85  |         |          |           |        |       |     |        |
| 86  |         |          |           |        |       |     |        |
| 87  |         |          |           |        |       |     |        |

| NO. | PROCESS | FUNCTION | SET POINT | SIGNAL | ALARM | PID | IN/OUT |
|-----|---------|----------|-----------|--------|-------|-----|--------|
|     | 0       | 100      | 200       | 300    | 400   | 500 | 600    |
| 88  |         |          |           |        |       |     |        |
| 89  |         |          |           |        |       |     |        |
| 90  |         |          |           |        |       |     |        |
| 91  |         |          |           |        |       |     |        |
| 92  |         |          |           |        |       |     |        |
| 93  |         |          |           |        |       |     |        |
| 94  |         |          |           |        |       |     |        |
| 95  |         |          |           |        |       |     |        |
| 96  |         |          |           |        |       |     |        |
| 97  |         |          |           |        |       |     |        |
| 98  |         |          |           |        |       |     |        |
| 99  |         |          |           |        |       |     |        |



NOTE

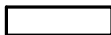

Read Only Location

## Notes



### Warranty and Return Information

Precision Digital warrants this product to be free from material defects and workmanship under normal use and service for three years.

Please contact Precision Digital Technical Support at (800) 610-5239 or e-mail at [support@predig.com](mailto:support@predig.com) prior to any product return. When Technical Support determines a product should be returned, a Return Material Authorization (RMA) # which must be included on the return shipping label. Please also include the reason for return, date of purchase, contact name, and how to contact. Products returned for reasons other than repair may be subject to a restocking fee. Any returns under a warranty claim should be returned freight prepaid. Upon warranty confirmation Precision Digital will repair or replace and return the unit at no charge via UPS Ground. Other shipping is available upon request and at customer expense. All product returns should be shipped to:

Return Authorization # \_\_\_\_\_  
Precision Digital, 89 October Hill Road Ste 5, Holliston, MA 01746 USA  
Attention: Technical Support

Precision Digital Technical Support is trained and eager to serve you. We have found most start-up problems to be the result of incorrect signal connections and/or programming. Most often Precision Digital Technical Support can quickly correct these issues over the telephone.

# How to Contact Precision Digital

- For Technical Support  
Call: (800) 610-5239 or (508) 655-7300  
Fax: (508) 655-8990  
Email: [support@predig.com](mailto:support@predig.com)
- For Sales Support or to place an order please  
Call: (800) 343-1001 or (508) 655-7300  
Fax: (508) 655-8990  
Email: [sales@predig.com](mailto:sales@predig.com)
- For the latest version of this manual, please visit  
**[www.predig.com](http://www.predig.com)**

